

CONDITIONS OF SALE AND WARRANTY

1. Read carefully this operator's handbook before operating our P35 corking machine.
2. M.E.P. guarantees his P35 corking machine in case of breakages caused by faulty components or incorrect assembly.
3. Our P35 corking machine has a 12-month warranty. 12 month period begins on shipping date from St. Patrick's of Texas. This guarantee is valid only for the first owner of the corking machine.
4. Warranty only consists in replacing the damaged parts and it does include neither refunds for losses caused by the shutdown of the machine nor any cost of labour or any transport cost to send the filling machine to a repair shop.
5. Any repair or modification made to the machine by unauthorized personnel will make the warranty void.
6. We cannot be held responsible for damages due to incorrect use of the corking machine, or failure to carry out maintenance and lubrication, or problems or damage incurred during transport.
7. M.E.P. reserves the right to introduce changes without previous notice to the P35 corking machine; however, the supply of spare parts of the previous models will be guaranteed.

INDEX

Description of the P35 corking machine.....	page 2
Operating directions.....	3
Technical details.....	4
Instructions for use.....	5
Vacuum / azote.....	7
Faults and remedies check list.....	9
Maintenance.....	12
Electric system of the P35 corking machine.....	14
Components of the P35 corking machine.....	
Components of the wheeled support.....	

DESCRIPTION OF THE P35 CORKING MACHINE

Our P35 corking machine meets the requirements of those wine-growers who need a rapid and precise corking.

Our P35 corking machine is almost entirely made of stainless steel to make cleaning easier. Moreover all those parts which could come into contact with the corks are made of materials that do not react with the air (such as stainless steel, plexiglass, chromium-plated steel), in order to prevent all chances of polluting corks with rust splinters or whatever other substances bad for health. Even the internal mechanisms, such as connecting rods and levers, are galvanized. All the parts which come into contact with the bottle are made either of rubber or pvc to avoid the breaking off of splinters from the glass.

The mechanisms that must bear heavier loads are supported by ball-recirculating or roller-recirculating elements in order to guarantee both a higher precision of functioning and a higher resistance to wear.

All moving gears are protected by safety guards and those parts which the operator must reach often, such as the cork container and the jaws, are fitted up with easily removable safety guards. The latter are equipped with a sensor so that the corking machine cannot work when these guards are removed.

SAFETY SYMBOLS:



General danger



Caution: refer to the operator's handbook



ndbook - P35 corking machine

Caution: 230 Volt tension.



Caution: rotating gears. Severing of fingers.

OPERATING DIRECTIONS

Our P35 corking machine is provided with an upper cork container which is fitted up with a mechanical mixing device that lines the corks up and pushes them through the descent duct for the corking to be carried out successfully. This corking machine positions the cork within jaws which squeeze it down to the size of the neck of the bottle. In this way less stress is needed to push the cork down into the neck of the bottle with the advantage of not damaging the cork itself that will expand once it is inserted and ensure a good seal.

To start the corking machine a bottle must be placed on the bottle platform, **the two starting push-buttons located on the sides of the machine must be kept pressed simultaneously for a couple of seconds** (see picture 1). In this way the working cycle starts off: the bottle platform goes up, the jaws go down and compress the cork which is afterwards inserted into the neck of the bottle by the cork-pushing pin (see picture 1). At this point the two push-buttons can be released to start the cycle of return off. This means the lowering of the bottle platform, the ascent of the cork-pushing pin and the rotation of the cork pusher which picks up a cork from the cork descent duct and drives it into the jaws ready to be used next time.

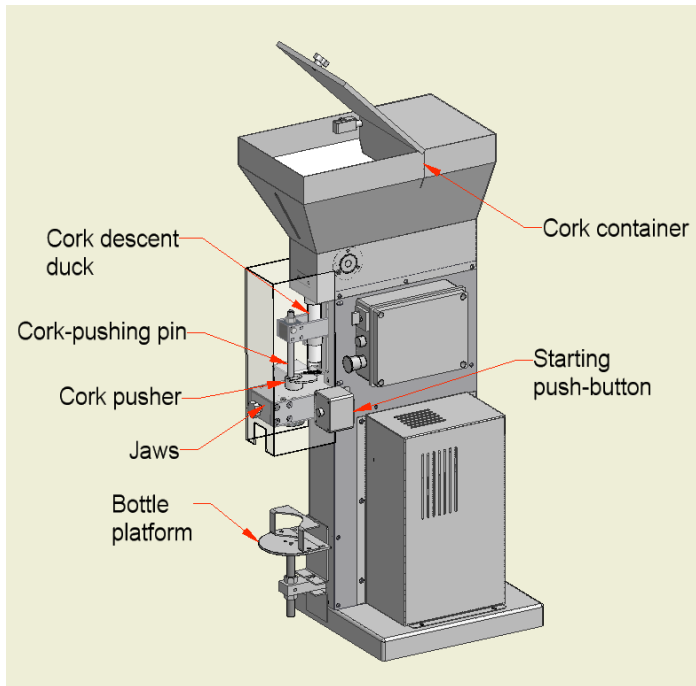

Picture 1.

TECHNICAL DETAILS

Standard equipment:

- cork size diameter 22-26 x 50 mm.
- bottle height up to 390 mm.
- corking time approximately 1,8 seconds

Optional equipment:

- cork descent duct and cork pusher for corks with diameter up to 28 mm.

P35 corking machine

Height: 1810 mm.

Width: 520 mm.

Length: 560 mm.

Weight: 126 kg.

Mono-phase motor:

Feeding: 110 Volt, 60 Hz

Speed rotation: 1380 r.p.m.

Power: 0,75 Kw

Screw reducer without end:

reduction ratio 1/40

INSTRUCTIONS FOR USE

- Positioning. The P35 corking machine should be placed on an even ground. Make sure that the screws which hold the safety guards are screwed tight, especially those which hold the switch-board.
- Clean all the parts that come into contact with the corks, such as the cork descent duct, cork pusher, jaws, cork-pushing pin and cork container (see picture 1).
- Check that no foreign matters which could compromise the good functioning of the machine are either inside the cork container or inside the jaws.
- Take off the antiscratch blue nylon film from the front plastic safety guard, tighten the fasteners and make sure the pin can activate the safety sensor (for the sensor of the jaws and the plastic pin of the safety guard, see picture 2).
- Adjust the height of the bottle platform by undoing the two bolts (see picture 2) which hold it tight, then re-tighten the bolts so that the top of the bottle is near the bottle-height line underneath the jaws.

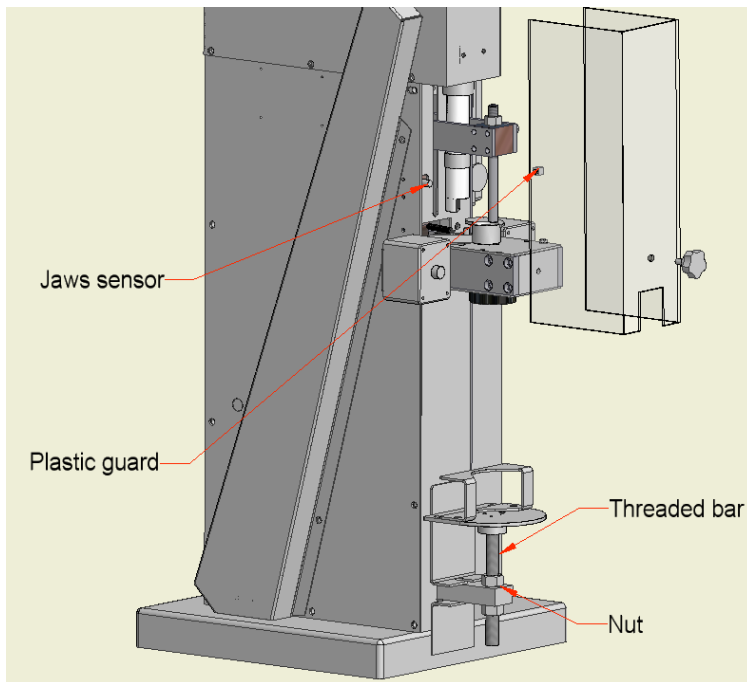

Picture 2.

Fill up the cork container and close the lid. When the lid is open, the respective sensor is not operated (see picture 3) and the corking machine cannot start.

Connect the feeding cable to a 110 volt current-tap, turn clockwise the quick-stop button of the switch-board and turn the starting switch to position 1 (see picture 4). Now a green light should be lit and the corking machine can be started by pressing the two starting push-buttons located on the sides of it (see picture 1).

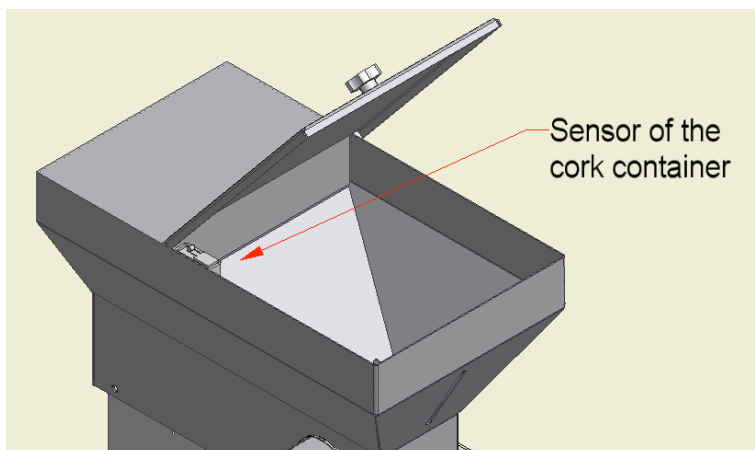

Picture 3.

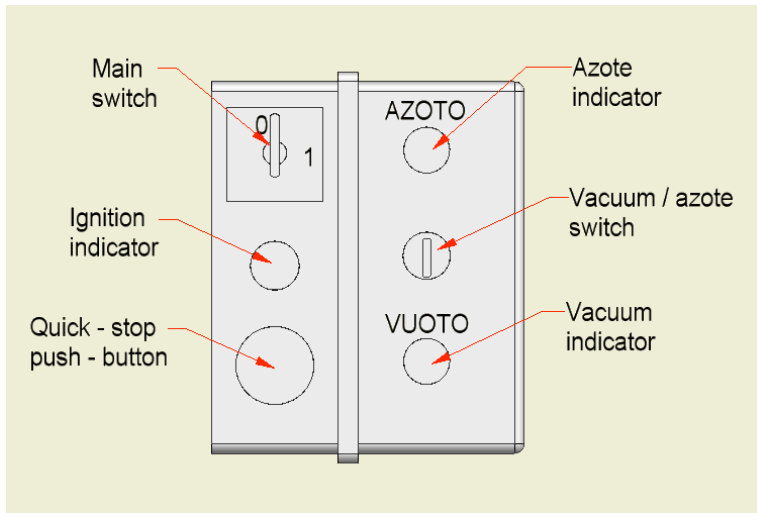

Picture 4.

CAUTION

The corking machine can be used by only an operator at a time and no one else should be near when the feeding cable is connected and the corking machine is operating.

In order to prevent any accident the two starting push-buttons must be kept pressed and both hands must be kept in this position until the corking operation has been carried out.

VACUUM / AZOTE

To suck up the air and obtain some depression between the cork and the wine, it is enough to turn the vacuum / azote switch until the green vacuum indicator lights up (see picture 4). By just pressing the starting push-buttons, it is possible to get both the bottles corked and some depression inside them. The depression is obtained by creating vacuum inside a tank by means of a pump and putting in transmission this tank with the bottle during the last part of the corking operation, that is when the bottle is in its upper position and is about to be corked. The vacuum level inside the tank is visualized on the vacuummeter and it is adjustable through the special knob (see picture 5: vacuum regulator). The vacuum level is proportional to the depression inside the corked bottle. It

is advisable to keep the vacuumeter on a value between -0,7 / -0,9 for corks and on a value between -0,6 / -0,8 for synthetic stoppers. Once the bottle is corked the depression inside the bottle can reach -0,4 bar compared to the atmospheric pressure.

Otherwise if you want to put in azote before the corking, connect the azote feeding hose to the special connection (see picture 5). Then turn the azote / vacuum switch to light the green azote indicator (see picture 4). In this case, the pressure can be adjusted through the regulator located on the azote bottle. It is advisable not to set values too high, such as 0,3 bar above the atmospheric pressure.

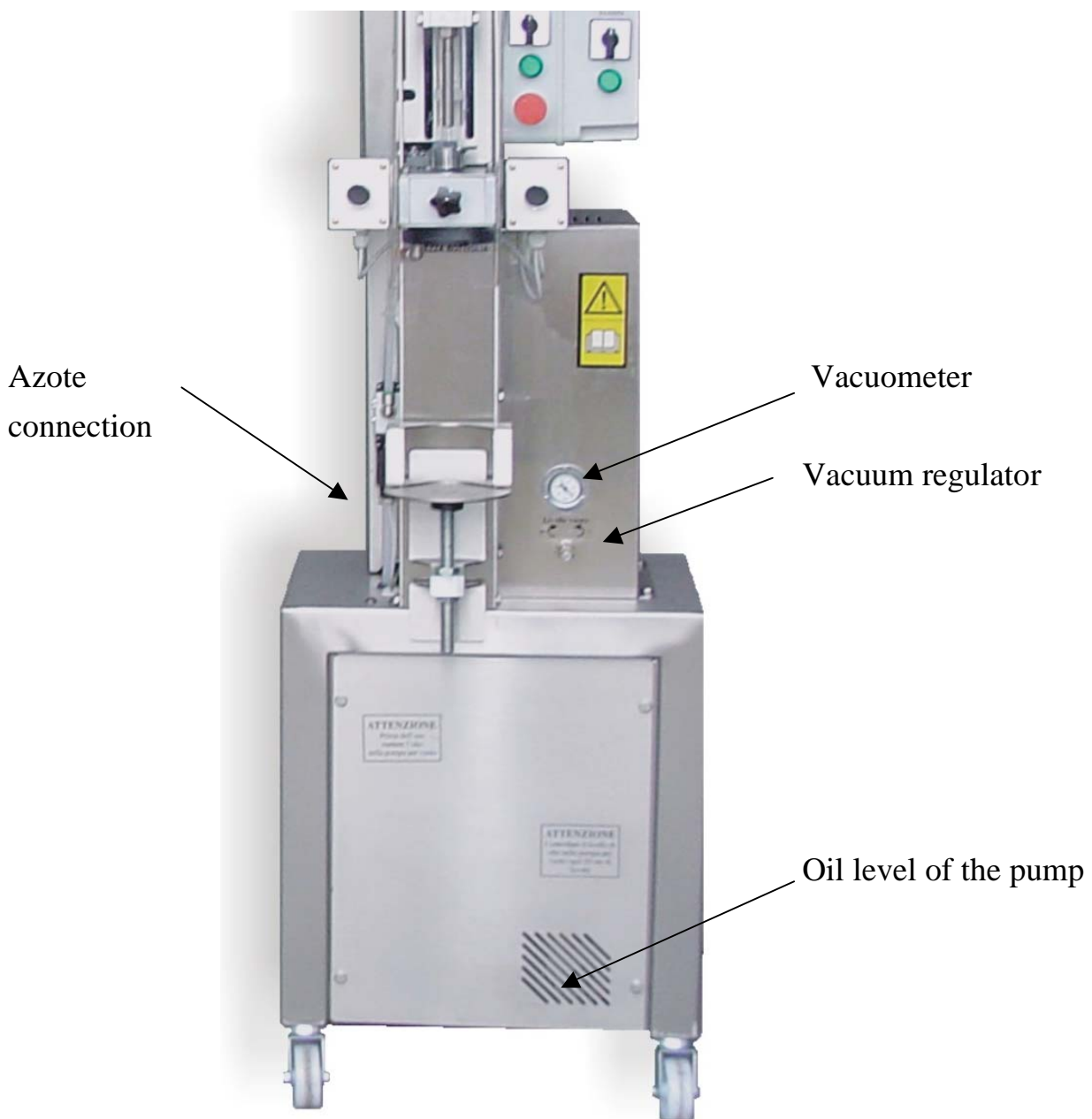

Picture 5.

CAUTION

It is important to check the oil level of the air-pump before starting work. The oil level of the pump can be checked through a round indicator that can be seen through the fissures of the wheeled support (see picture 5: oil level of the pump); in order to obtain proper functioning, the oil level inside this indicator must be at about half-way.

The oil level has to be checked at least every 20 working hours.

FAULTS AND REMEDIES CHECK LIST

- When the machine is operating the green light (see picture 4) must be on. If it is not so, you must check that the pin of the plastic front guard starts the respective sensor in the correct way and the lid of the cork container is closed.

- It should be noted that once the quick stop push-button is pressed, it stays pressed and in order to release it, it must be turned clockwise. For this reason, if the machine doesn't start, it may have been pressed the push-button by mistake; in this case, turn it and try again.

- If one tries to remove the plastic guard or to open the lid, the green light goes off, the machine stops immediately and the bottle-stand remains half-way of its stroke. In order to bring the bottle-stand to its starting position, one must relocate the guards or the lid and press the starting push-buttons.

IMPORTANT

Before intervening on the machine always bring the starting switch back to the "0" position and disconnect the feeding cable.

- If at the end of the corking operation the bottle-stand doesn't go to the lower position of its stroke, open the left side of the machine (it is meant left being in front of the machine). Loosen the grain of the end-of-stroke-element (see picture 5) and try to turn it; if one turns it clockwise the end of the corking cycle is anticipated (the bottle-stand reaches its lower point and tends to go up), if you turn it anti-clockwise the end of the corking cycle is delayed (the bottle-stand doesn't reach its lower point). Re-tighten the side down and re-start the machine.

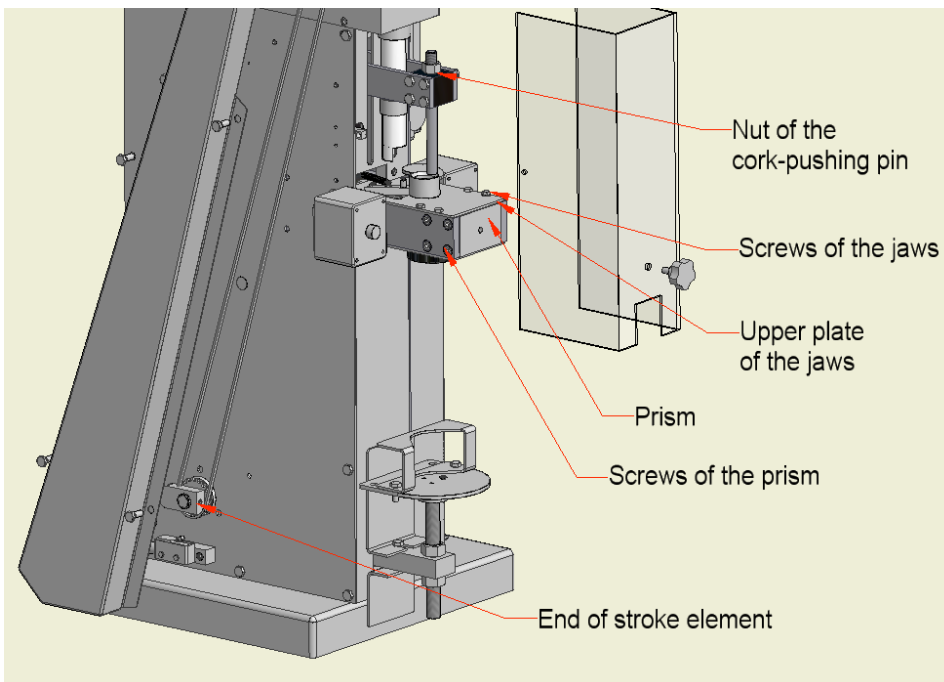

Picture 6.

- If the corks don't go down the cork descent duct correctly open the lid of the cork container and mix the corks.

- In case the corks are not picked up precisely by the cork pusher, it is necessary to adjust the stroke of the cork pusher itself (the cork pusher is fastened to the upper plate of the jaws) (see picture 6: screws of the jaws). To do this, the six upper screws of the jaws must be loosened and the upper plate of the jaws can be moved towards the corking machine or in the opposite direction. Tighten the screws and start the machine; if the result is not satisfying, repeat the operation.

- If it is needed the cork to be inserted deeper or higher in the neck of the bottle, the fastening nut must be loosened and the cork-pushing pin turned: the last is threaded then it can be moved up and down. Before starting the machine again, the fastening nut must be tightened (see picture 6).

In case one does not succeed in carrying out the above mentioned adjustment (especially it could not be successful with synthetic stoppers) it is advisable to adjust the tightening of the jaws.

Our P35 corking machine is set to compress the corks to a diameter of 16 mm.

- When the jaws are tightened and the cork-pushing pin starts to push a cork down, it may happen that the bottle-stand cannot keep its position and tends to go down so that it doesn't allow the cork to be fully inserted. In this case it is the ascent system of the bottle stand that needs maintenance. It is necessary to remove the bottle stand by loosening the bolts; the mobile guard plates and the lower guard plate must be removed too (see picture 7): the cylindrical rod on which the bottle stand moves up and down must be cleaned (see picture 7). It is advisable to use a dry cloth and rub vigorously to remove whatever dust. Then it's a good rule to lubricate the cylindrical rod with a drop of oil (and not more, one should never exaggerate with the lubrication). In case the machine vibrates a little, one should lubricate the inside of the jaws and let the machine do a couple of blank strokes. Before starting work it is better to clean the jaws to prevent the oil from dirtying the corks (see picture 1).

If the vibrations continue it is advisable to loosen the bolts of the back guard (reference 108 on the table "Components of the P35 corking machine") and lubricate all the pins and bearings inside. In case the problem persists turn to the manufacturer.

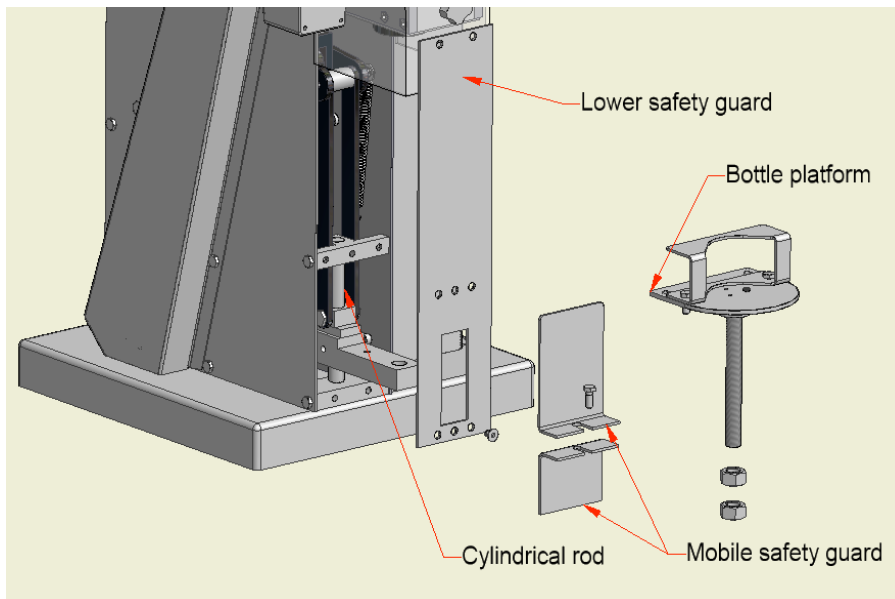

Picture 6.

CAUTION

In the event of strong vibrations of the machine immediately push the quick-stop push-button and contact the local dealer.

MAINTENANCE

A long machine working life is dependent upon constant and methodical compliance with the following instructions:

- take off the back plate (reference 108 on the table "Components of the P35 corking machine") and lubricate the bearings, the slide and the pins inside the machine;
- clean the jaws from any cork dust;
- lubricate the inside of the jaws and remove the excess oil before starting work.

At the end of each season we recommend to:

- carefully clean the machine and the jaws;
- store the machine in a dry place and cover it up with a cloth or a nylon film in order to prevent the dust from crusting over the corking machine.

ELECTRIC SYSTEM

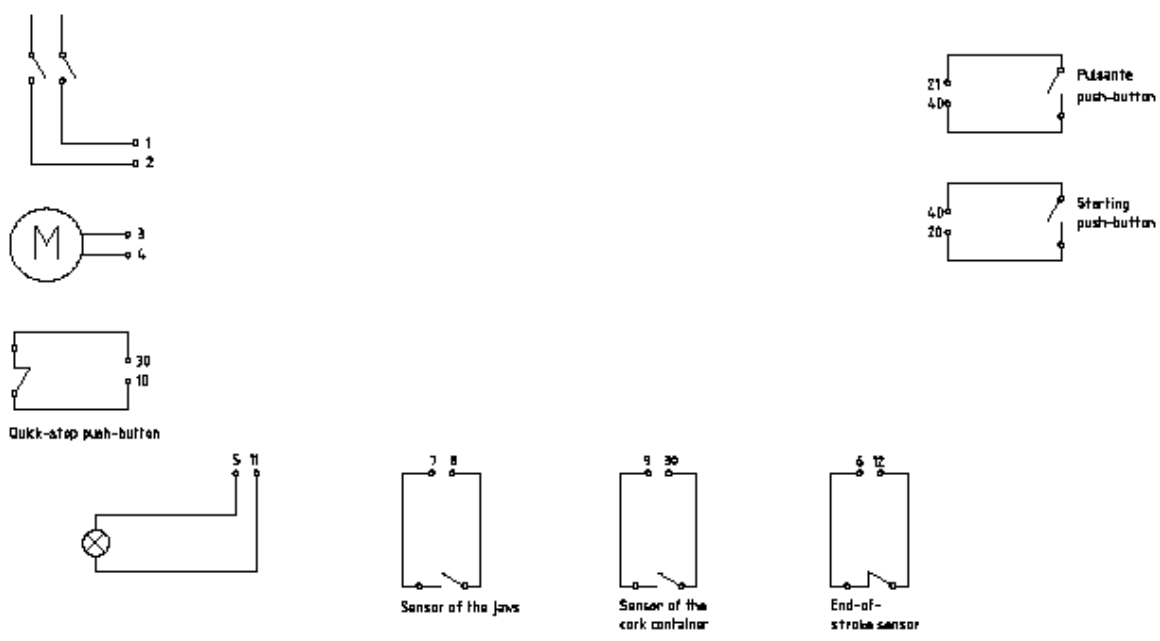
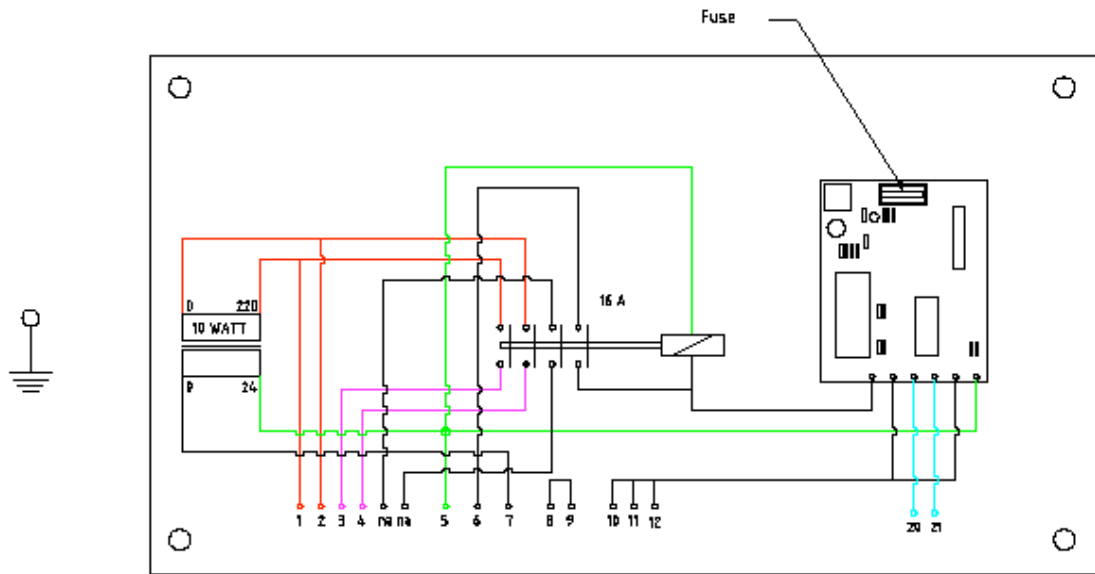

ELECTRIC SYSTEM FOR VACUUM

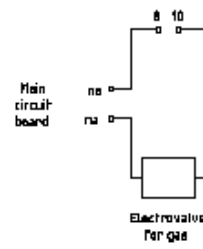
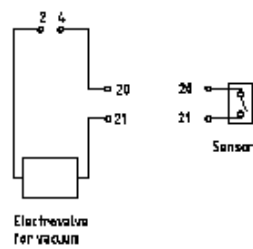
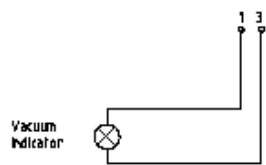
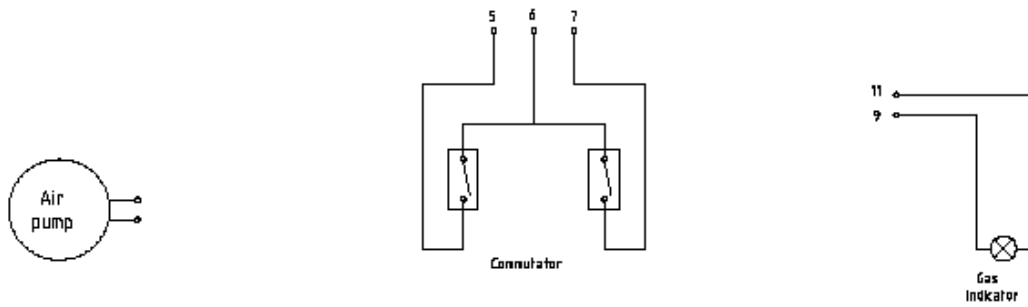
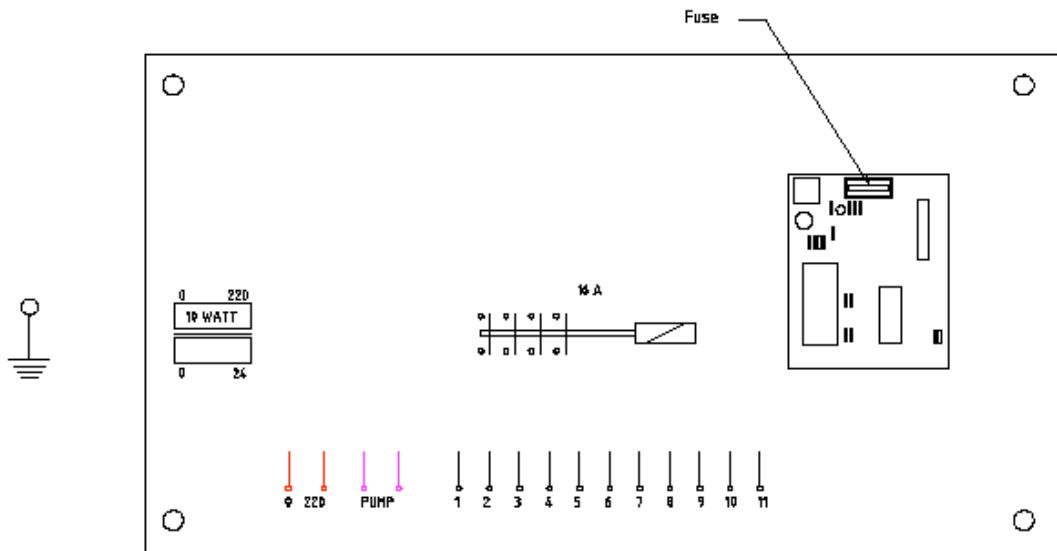

POS.	DESCRIPTION	REF.	POS.	DESCRIPTION	REF.
1	0,75 KW motor	tap0201	35	Base	tap1028
2	Reducer	tap0202	36	Push-button sensor	tap0225
3	Flange	tap0203	37	M4x30 screw	tap0309
4	Motor guard	tap1317	38	Support	tap0502
5	Right side plate	tap1301	39	10 mm. diam. pin	tap1024
6	M10x25 screw	tap0301	40	M10 washer	tap0310
7	M8x16 screw	tap0302	41	10 mm. diam. elastic ring	tap0210
8	Washer	tap0303	42	Cork-pushing pin	tap1315
9	M10 nut	tap0304	43	M18 nut	tap0326
10	SBPF 205 support	tap0204	44	Connection	tap1313
11	8x7x40 tongue	tap0205	45	Side plates	tap1312
12	Cam shaft	tap1031	46	M12 nut	tap0311
13	HK 6020 roller-shell	tap0206	47	Upper safety guard	tap1319
14	Engine connecting rod	tap1005	48	Connection	tap1043
15	60 mm. diam. elastic ring	tap0207	49	Lever	tap1304
16	Spring	tap0005	50	Connecting rods	tap1336
17	M8x30 cylindrical head screw	tap0305	51	15 mm. diam. pin	tap1023_2
18	M8 nut	tap0306	52	15 mm. diam. elastic ring	tap0211
19	M6 threaded pin	tap0513	53	Spacer	tap1007
20	Connecting rod	tap1308	54	18 mm. diam. pin	tap1003
21	Reference for bottle	tap0508	55	Spacer	tap1322
22	M10 washer	tap0307	56	Spacer	tap1323
23	Connection	tap0505	57	15 mm. diam. pin - short model	tap1023_1
24	Brake	tap0506	58	Spacer	tap1329
25	Brake connecting rod	tap0507	59	15 mm. diam. pin - long model	tap1324
26	Bottle platform-holder	tap0504	60	Pin	tap1325
27	Handgrip with M8x16 screw	tap0208	61	Connecting rod	tap1307
28	Spring	tap0006	62	Lever	tap1305
29	Bottle platform	tap0509	63	Cork descent duct	tap1213
30	M8x20 screw	tap0308	64	Connection	tap0213
31	Back plate	tap1032	65	Slide	tap1211
32	Threaded spacer	tap1036	66	SBPF 203 support	tap0214
33	Front plate	tap1025	67	Right side plate	tap1214
34	Cylindrical rod	tap0501	68	Tongue	tap1210

POS.	DESCRIPTION	REF.
69	Spring	tap0008
70	Spacer	tap1212
71	Left side plate	tap1215
72	Shaft	tap1209
73	Cork container	tap1201
74	Pinion	tap0215
75	Threaded handgrip	tap0216
76	Left flank	tap1302
77	Sensor	tap0217
78	Sensor guard	tap0218
79	SKF 4302 bearing	tap0226
80	Sensor support	tap1018
81	M6x20 cylindrical head screw	tap0312
82	SBPF 204 support	tap0219
83	End of stroke cam	tap1019
84	Spacer	tap1029
85	Pinion	tap0220
86	8 mm. - pitch chain	tap0221
87	Chain guard	tap1316
88	Connection	tap1337
89	Push-buttons	tap0227
90	Plastic guard	tap0714
91	Spring	tap0007
92	Cork pusher	tap0801
93	SKF 625-2Z bearing	tap0228
94	M8x16 cylindrical head screw	tap0313
95	Upper plate	tap0709
96	Fork	tap0702
97	Prism for jaws	tap0701
98	Spring-loaded angle bar	tap0705
99	Threaded angle bar	tap0704
100	Side plate	tap0706
101	Lower mobile guard	tap0512
102	Lower plate	tap0708

POS.	DESCRIPTION	REF.
103	Spring	tap0004
104	Cone	tap0713
105	Block	tap0719
106	Lower safety guard	tap1320
107	Mobile upper safety guard	tap0510
108	Back safety guard	tap1321
109	M4x10 cylindrical head screw	tap0327
110	M8x20 cylindrical head screw	tap0334
111	M5x45 cylindrical head screw	tap0315
112	M5 nut	tap0316
113	M8x10 screw without head	tap0317
114	M4x6 countersunk head screw	tap0336
115	M5x30 screw	tap0319
116	M10x20 cylindrical head screw	tap0328
117	M6 nut	tap0321
118	5x30 elastic pin	tap0224
119	M4 nut	tap0329
120	M8x8 countersunk head screw	tap0322
121	M6x25 screw	tap0335
122	Electric panel	
123	M6x12 screw	tap0324
124	M4x16 countersunk head screw	tap0325
125	Washer for M16 screw	tap0330
126	M5x20 cylindrical head screw	tap0331
127	Spacer	tap0716
128	M6x8 screw without head	tap0332
129	M5x12 countersunk head screw	tap0333
130	Fork	tap1310
131	Moving part	tap0229
132	Slide	tap0230
133	Wedge	tap1309
134	Plate	tap1314
135	Bushing	tap0514
136	M18 threaded bar	tap0231

COMPONENTS OF THE P35 CORKING MACHINE

COMPONENTS OF THE WHEELED SUPPORT

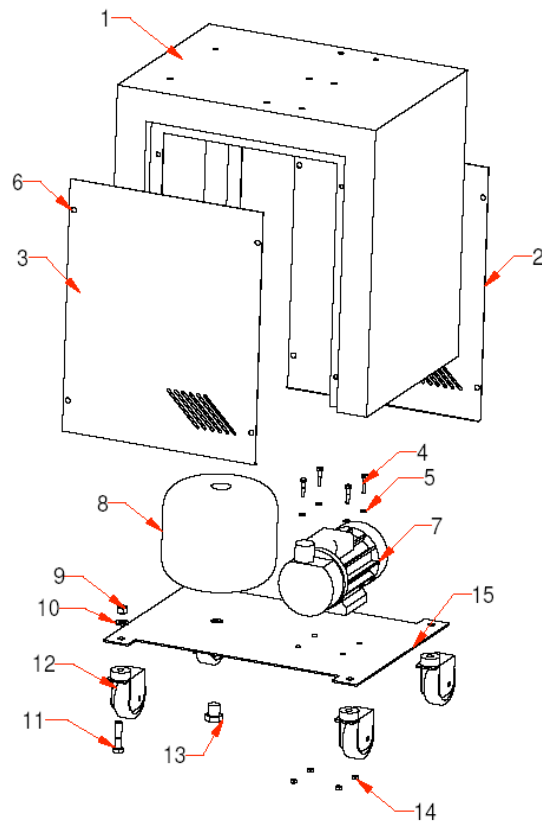

POS.	DESCRIPTION	REF.
1	Frame	tap1330
2	Back plate	tap1332-1
3	Front plate	tap1332
4	M6x25 stainless screws	tap0347
5	Washer for M6 screw	tap0330
6	M8x16 stainless screw	tap0302
7	Air-pump	tap0232

POS.	DESCRIPTION	REF.
8	Vacuum tank	tap0233
9	M12 nut	tap0346
10	Washer for M2 screw	tap0345
11	M12x35 screw	tap0344
12	Plastic wheel	tap0238
13	Valve 1/2 for gas	tap0239
14	Stainless steel M6 nut	tap0321
15	Tank connection surface	tap1331